

# Officina Meccanica **BETA**

Via Edison 1/3 - C.P. 64 - Legnano (MI) - ITALY  
Tel. +39.0331.595300 - Fax +39.0331.547491 - E-mail info@betaspa.com

---

**NEW MODEL**

## **HORIZONTAL DYEING PADDER**

**Equipressure rolls**

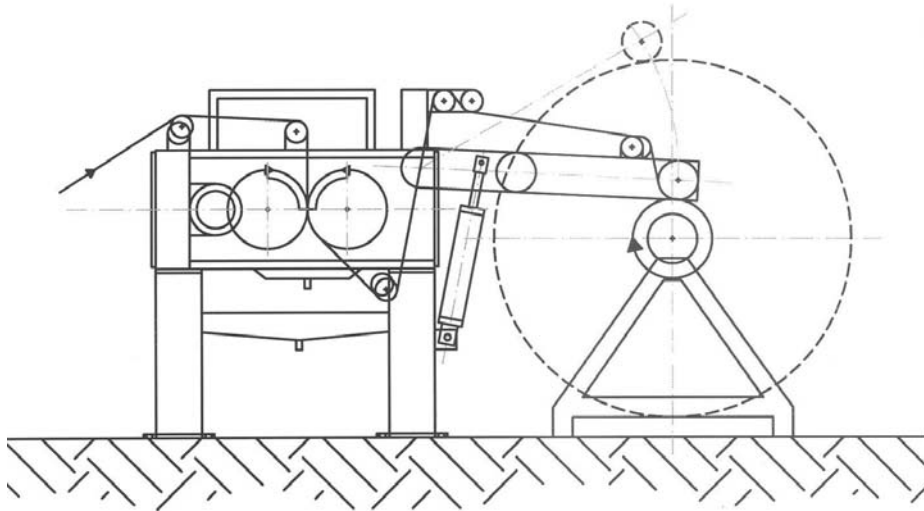

### **Technical features:**

- Dyeing padder type FMC-2-O with horizontal rolls layout
- Equipressure BETA rolls, Ø 400mm, parallel grinding, rubber coating PBC-N 75 Sh. A
- Working pressure 80kg/cm
- Speed 80m/min
- AC drive by inverter
- PLC with manual mode and automatic sequences for production and rolls' cleaning
- Upper safety guard with sliding doors and switches with electromagnetic door locking
- Automatic pressure regulators with 0-10V signal (rolls and lateral seals pressure control)
- Fabric inlet from above
- Watertight stainless steel lateral seals, pneumatically actuated, and lateral ducts to the trough
- Fixed trough for dyeing liquid catchment
- Capacitive level to control the feeding pump of dyeing liquid
- Curved spreader rollers fitted on machine and on winder device
- Tangential winder device 2,2kW with constant tension by load cells (reel Ø 1800mm max)