

Officina Meccanica BETA

Legnano - ITALY

Via Edison 1/3 - C.P. 64 - Tel. 0331 595 300 - Fax 0331 547 491

NEW MODEL

MODULAR TWIN PADDER

Equipressure type for squeezing and dressing

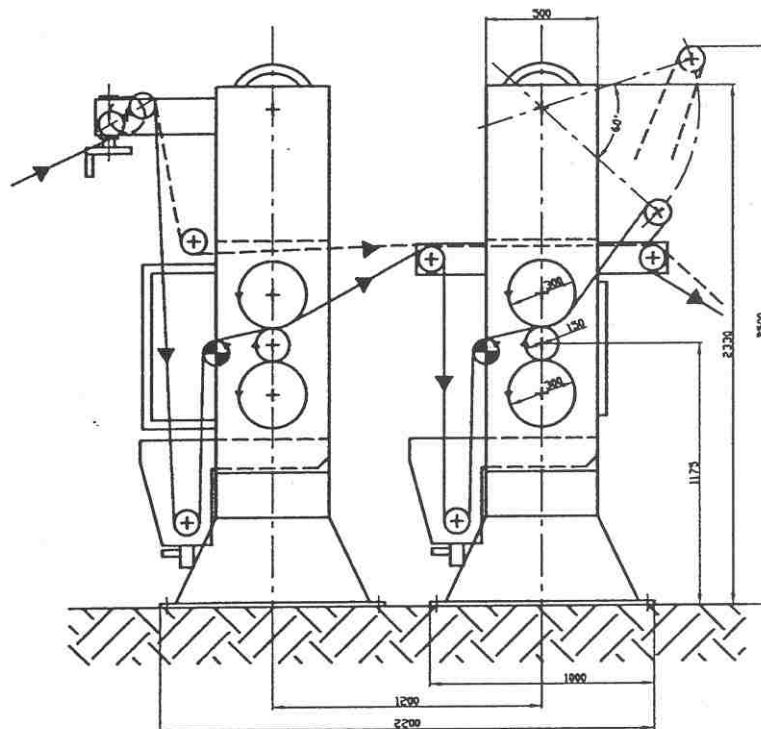

Characteristics:

- Wide versatility: the Twin Padder (3+3 bowls) is available for each type of fabric.
- Easily separable into two stand-alone padders so that it is possible to face any future production need (for this reason the machine is provided with two independent cabinets for driving control).
- Minimum size: distance between the two bowls' groups is 1200mm (or more, if needed).
- Usage flexibility: possibility to work with one squeezing group alone (both first and second group) or by using both squeezing groups.
- High squeezing performance: max linear pressure equal to 100kg/cm and central roller with low diameter achieve together the greatest specific pressures and the minimal width of the bowls' contact zone.
- Absolute squeezing uniformity for any working pressure: patented BETA bowls have zero deflection along their whole span and are parallel ground.
- Great accessibility for maintenance, disassembling, cleaning and for fabric drawing-in.
- Excellent visibility: possibility to inspect the fabric along all its path.
- Reduction in operating costs: the upper and lower bowls are exactly alike and interchangeable each other; this fact gives a great flexibility in facing eventual unexpected accidents and allows the reduction of the periodical rubber grindings.
- Intermediate synchronization with load cells or synchronization roller; outlet with synchronization roller.